

Technology Concepts for Next Generation VLA

Workshop, Pasadena, April 8, 2015

Overview

Sander Weinreb

1. Evolution of the VLA
2. SKA status
3. ngVLA rationale
4. Comparison with JVLA, ALMA, and SKA1_Mid
5. Operating cost challenge
6. Technology challenges
7. Future workshops

VLA to NGVLA Evolution

	VLA Proposal	VLA As Built	JVLA	NGVLA
Year	1967	1980	2011	2030
Antennas	36x25m	27x25m	27x25m	256x18m
Receivers	2	4	8	1
Frequencies, GHz	2.7, 8.1	1.4, 5, 15, 23	1 to 50	1.2 to 116
Tsys, K	100	34 to 110	26 to 66	30 to 60
Processed bandwidth, GHz	.01	0.1	8	50
Sensitivity, μJ * root sec	11,340	1219	136	32
Highest Resolution arc seconds	.36	.13	.06	.006

Square Km Array, SKA – Status

- A large International radio astronomy project with 11 member countries to build future arrays in Australia and S. Africa - See www.skatelescope.org
- Sensitivity will be 100 times greater than existing radio telescopes
- Intended to be built in two phases, but only phase 1 is well-defined.
- Schedule and cost caps
 - 2013-2016: Detailed design. Spending ~€125M.
 - 2018-2023: Phase 1 construction. Cost cap €650M.
- Phase 1 consists of two telescopes described in the next 3 slides:
 - **SKA1_mid**
 - **SKA1_low**

SKA1-mid

- 133 15m dishes + 64 13.5m dishes located in S. Africa,
- 0.35 to 13.8 GHz in 5 bands
- Precursor instrument is Meerkat, 64 x 13.5m dishes



2014 SKA Engineering Meeting

Fremantle, Western Australia

- Attended by approximately 300 people, 8 from the US
- 2013 was in Manchester; 2015 to be in S. Africa



Apr 8, 2015

ngVLA Technology - Overview -
Weinreb

SKA Organization

- **Members:** Australia, Canada, China, Germany*, India, Italy, New Zealand, South_Africa, Sweden, The Netherlands, United Kingdom.
 - * Germany may drop out; submitted formal 12 month notice in mid-2014.
- **Others:** France is expected to join. There are “participating organizations” in 8 other countries, including the US, mostly industry.
- **Structure:**
 - Governing board consisting of representatives of member countries, one vote per country.
 - Central organization (SKAO) with HQ at Jodrell Bank, in new building funded by UK. Non-profit corporation under UK law. Around 50 employees. Funded 2012-2015 by cash from members totaling €23.M. Director General is Phil Diamond. SKAO has authority over the technical design, but does not control the flow of money.
 - Ten “Consortia” of organizations (mostly universities and government labs) doing actual work of pre-construction, with each funded directly by its own country. Most consortia are multi-national.
 - Structure may be different during construction. It is hoped that a larger fraction of cost will flow through the central organization.

Lessons Learned: Why Did the US Drop Out of SKA?

After spending \$13M on a Technology Development program, 2006-2010

- **Timing**
 - At the time of the 2010 decadal review the US was funding two large radio astronomy projects – ALMA and JVLA – and could not afford another.
- **Poor Technical Readiness and High Cost Estimate**
 - The US SKA project submitted a poorly supported cost estimate of \$2.2B and this was increased to \$5.9B by an outside review. The international SKA split the project into two phases with SKA1 capped at \$0.75B
- **Insufficient Focus**
 - Conflicts over multiple science drivers and which array to propose.

Development of a Higher Frequency Part of the SKA was Recommended in the US 2010 Decade Review

Excerpt from the RMS Panel section of the 2010 Decadal recommendations:

“The short-wavelength (0.6-3.0 cm) part of SKA helps constrain dark energy (CFP-2), dark matter (CFP-3), galaxy evolution via CO and other molecules at z above 1.3, (GCT-2), planet formation (PSF-2), and the ends of massive stars (SSE-3).

*Because of the U.S. heritage with EVLA, GBT, VLBA and ALMA, it is natural for the U.S. to build on these in developing this part of SKA. **A modest program of technology development and prototyping should begin in this decade.** The NAA activity discussed earlier provides an attractive way to proceed.”*

Critical Factors Needed for ngVLA

Compelling Science Case - Must show transformational science to convince the wide astronomy community that this is the “next big thing” that is needed to keep the US at the forefront.

Concurrent Technology Development - Show cost factors, tradeoffs, and new opportunities to guide science requirements.

Reduced Operating Cost -The proposed wideband feeds and receivers greatly reduce operating cost. One cryogenic dewar per antenna is proposed per antenna rather than 8 on the present JVLA. Location in New Mexico rather than a high-altitude foreign site also reduces operating cost to a goal of 4% of the capital cost.

Tight management by NRAO of the construction and operation of the array to avoid necessary inefficiencies which occur in international projects. Development work by universities and institutions in the US and other countries is most welcome to utilize available expertise and train future scientists and engineers. A strong collaboration with China to utilize economical antenna manufacturing is recommended.

Science Requirements – Level 0 Specifications

From AAS science workshop, *Science with the Next Generation VLA*, Jan 4, 2015, major recommendations:

- Provide 5 times the sensitivity of the JVLA
- Increase the baseline length to 300km
- Operate in the 1 to 120 GHz range

Technical Requirements – Level 1 Specifications

Rationale for a 1.2-116 GHz, 256 x 18m ngVLA

1 Fill the Gap - The 13.8-116 GHz range fills the gap between SKA and ALMA.

2 Overlap with JVLA and SKA1-Mid for 1.2-13.8 GHz - gives a capability similar to SKA1_Mid in the prolific frequency range of the current JVLA.

3 Comparison with existing arrays and SKA - See Table I.

Note the point source sensitivity and survey speed improvements of 5 and 50 relative to JVLA at 10 GHz and 19 and 162 compared to ALMA at 80 GHz.

4) Simultaneous Frequency Range – Wideband receivers and a 50 GHz correlator provide unique science capability for spectral lines searches of red shifted lines or new molecular lines, single-event transient sources, and spectral index surveys. For most continuum observations the entire band would be processed in octave segments but these can be simultaneous (or commensal) so there is a advantage of the wideband receiver. The wideband would also be multiplexed into narrower bands after the LNA to use narrower bandwidth A/D converters and digital links.

Sensitivity and Survey Speed of ngVLA Compared to JVLA, ALMA, and SKA1

At 1.4 GHz ngVLA would have 8x the sensitivity and 124x the survey speed of JVLA
 At 10 GHz ngVLA would have 5.1x the sensitivity and 50x the survey speed of JVLA
 At 80 GHz ngVLA would have 19x the sensitivity and 162x the survey speed of ALMA
 ngVLA would be comparable to SKA1-mid at 1.4 and 10 GHz

							Figures of Merit		Comparisons of Figures of Merit	
Array	N	D(m)	Tsys(K)	Freq Range, GHz	Comparison Frequency, Fo, GHz	BW (GHz)	Point Source PSFOM	Survey SSFOM at Fo	Point Source Sensitivity Comparison	Survey Speed Comparison
MeerKat	64	13.5	18	0.58-14	1.4	1	648	207.4		12.1
SKA1-Mid	190	14.5	18	0.35-13.8	1.4	1	2219	2108.3	6.4	123.4
JVLA	27	25	49	1-50	1.4	1	344	17.1	1.0	1.0
ngVLA	256	18	30	1.2-116	1.4	1	2765	2123.4	xJVLA 8.0	xJVLA 124.3
SKA1-Mid	190	14.5	22	0.35-13.8	10	5	4060	7056.8	2.6	20.7
JVLA	27	25	31	1-50	10	8	1540	341.4	1.0	1.0
ngVLA	256	18	30	1.2-116	10	8	7820	16986.9	xJVLA 5.1	xJVLA 49.8
ALMA	54	12	80	31-950	80	8	275	47.2	1.0	1.0
ngVLA	256	18	100	1.2-116	80	40	5246	7644.1	xALMA 19.1	xALMA 161.8

PSFOM = Point Source Figure of Merit = $N \cdot D^2 / T_{sys} \cdot BW^{0.5}$

SSFOM = Survey Speed Figure of Merit = $(\lambda/D)^2 \cdot N_b \cdot (N \cdot D^2 / T_{sys})^2 \cdot BW = ((\lambda/D)^2 \cdot N_b \cdot (PSFOM)^2)$

Fo is the frequency for evaluation of FOM's. which is proportional to Fo^{-2}

Ratio's to JVLA are for the same center frequency, Fo, at 1.4 and 10 GHz; ratio's to ALMA are at 80 GHz

Technical Challenges for the NGVLA

Goals are verified cost and performance by 2019

- **Reflectors** – Cost vs diameter. Who builds it where out of what
- **Feed** - Good efficiency and 8:1 frequency range
- **LNA's** – Very low noise from 1.2 to 116 GHz
- **Correlator** – Cost and power consumption to achieve >500 times the processing power of the JVLA correlator.
- **Data Transmission** – 300 km with 50 GHz bandwidth

Low Operating Cost Requirement

The goal of the ngVLA can be operating cost no higher than the current JVLA. This is feasible for the following reasons

- **Fixed Antenna Locations** – Moving antennas adds to the operating cost of the JVLA and ALMA. The ngVLA will have fixed antenna locations which reduces the antenna cost as well as the operating cost.
- **Single Dewar per Antenna** – The antenna optics is designed such that small, completely-cooled feeds can be located close together in one dewar with one cryocooler. The JVLA has 8 cryocoolers per antenna and this is a heavy maintenance item.
- **Modern Electronics Design** – Utilization of multi-chip packaging such as modern consumer technology (TV's, cell phones) results in low manufacturing cost and also easy plug-in replacements.
- **Minimize Life Cycle Costs** – Mechanical wear and lubrication needs are known and can be designed for low maintenance.

Multi-chip MMIC Modules to Reduce Cost of ngVLA Electronics

Microwave functions performed by monolithic integrated circuits (MMICs) are orders of magnitude smaller and less expensive than conventional discrete components.

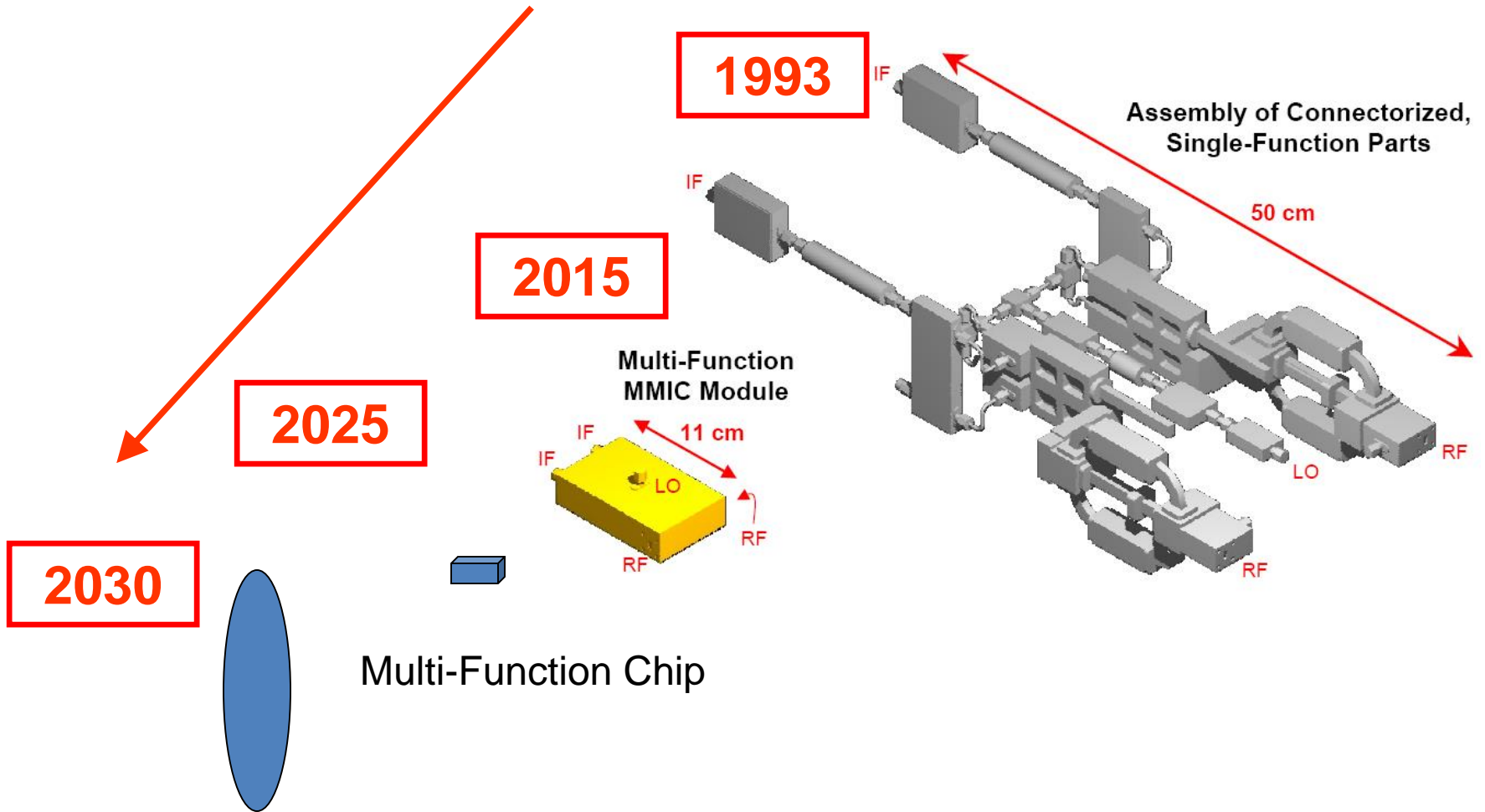

Multi-Pixel Array Wafer

ngVLA System Block Diagram

ANTENNAS

CRYOGENICS DEWAR

WARM ELECTRONICS

DATA TRANSMISSION

SIGNAL PROCESSOR

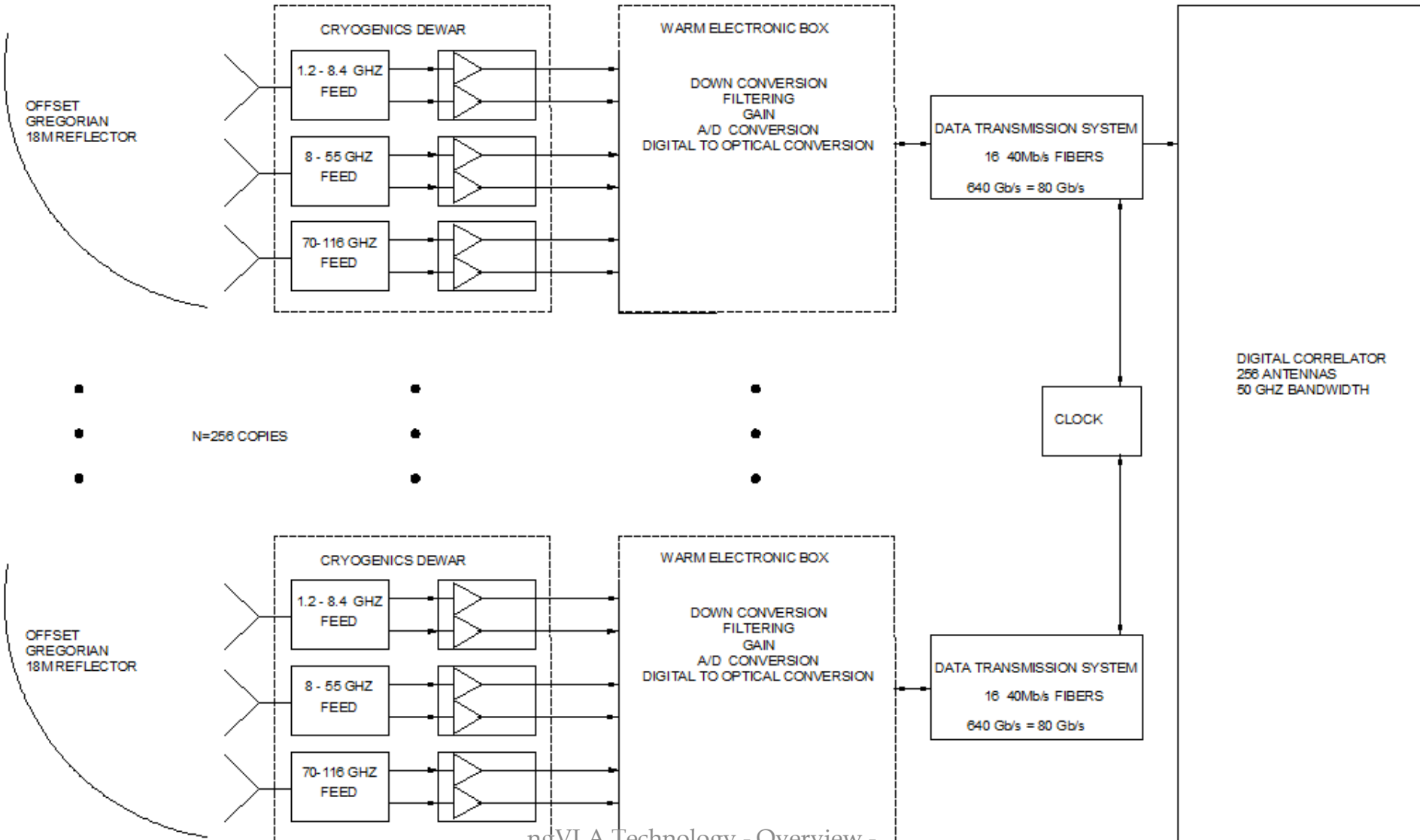

Apr 8, 2015

ngVLA Technology Overview

Weinreb

Topics for Future Technology Workshops

- **Array Configuration** – Fraction of antennas outside of a given distance, optimization of side lobe level
- **Data Transmission** – Cost per km, routes and installation methods
- **Clock or Local Oscillator Distribution** – Round trip, phase-corrected transmission is needed. Can build upon JVLA, ALMA Merlin, and SKA designs but lengths >100km require bi-directional repeaters.
- **Post-Processing Needs** – Fast, limited time duration data base for transient searches and slower data base archive.
- **Accuracy and Stability Specifications** – Antenna surface, antenna pointing, polarization, and receiver stability.

University Connection to ngVLA

- Training of future astronomers and engineers to design, construct, and operate a large array at NRAO.
- Develop, quantify, and document the astronomical applications for the NGVLA. Perform pathfinder observations to better understand the requirements and limitations.
- Design and prototype key elements such as feeds, LNA's , correlator components, and fiber transmission systems.